

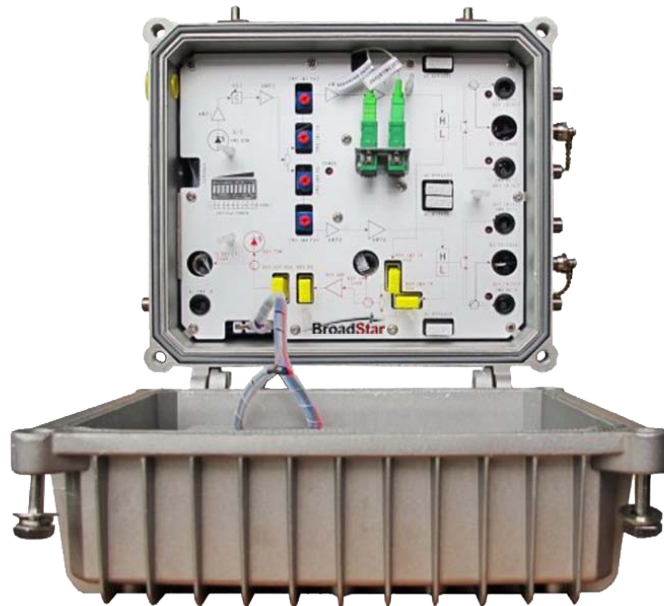

## **BON-870WR4 NETWORK NODE**



## **1.0 Product Description:**

The Broadstar Network Node is designed for today's HFC and Fiber Deep network applications. The node has four independent equalization stations that are adjustable giving the operator maximum control for their network needs. As in all Broadstar products, the node possesses superior components to insure optimal performance.

## **2.0 Product Features:**

- ▶ Waterproof outdoor aluminum casing w large fins for optimal heat control.
- ▶ Bi-direction transmission with optional outputs 1-4mW.
- ▶ Input power range -9~+2dBm for greater flexibility.
- ▶ Four outputs, independently controlled.
- ▶ Return path transmitter power 1~4mW.
- ▶ Adopt low noise pre-amplifier module for lower power receive situation.
- ▶ Final stage amplification use power doubled module to get high nonlinearity features.
- ▶ LED internal lighting for quick reference by technician.

### 3.0 Technical Index:

Parameter		Unit	Index	
Optical Parameter	Forward Path	Wavelength	nm	1100~1600
		Input Power Range	dBm	-9~+2
		Return Loss	dB	≥45
		Connector Type		SC/APC Or FC/APC
	Return Path	Wavelength	nm	1310±10
		Transmitter Power	mW	1~4
		Return Loss	dB	≥45
		Connector Type		SC/APC Or FC/APC
RF Parameter	Forward Path	Frequency	MHz	55/87~862 Or 55/87~750
		Flatness	dB	±0.75
		Impedence	Ω	75
		Return Loss	dB	≥16
		Attenuation	dB	Insertter chosen
		Slope		Insertter chosen
		Output Level	dB	45
	Return Path	Frequency		5~40/65
		Flatness		±1
		Impedence	dB	75
		Return Loss	dBuV	≥16
		Attenuation	MHz	Insertter chosen
		Slope	dB	Insertter chosen
		Input Level	dBuV	>85
Link Parameter	Forward Path	Channels		PAL-D/60ch
		CNR	dB	>50
		CTB	dBc	≤-62
		CSO	dBc	≤-65
	Return	Channels		PAL-D/60ch

	Path	CNR	dB	>50
General Parameter		Voltage	V	AC180V ~ 250V/AC60V
		Power Loss	W	<50
		Working Temp.	°C	-10 ~ 50

P.3

#### 4.0 Block Diagram:

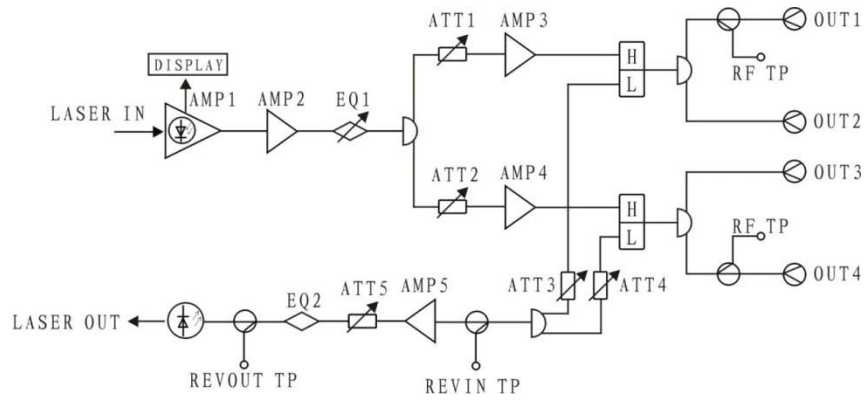

P.4